

# edp Minibagger

with Reversing Conveyor



Two Variable Speed Feed Belts  
Inch Top Up Function  
Will Feed Automatic Bagger

NOW WITH TOUCH SCREEN!

1- 5 Kg  
(6/8 bpm)

Onions • Potatoes  
Citrus • Tomatoes  
Avocados



70  
1947-2017  
edp

[www.edp.com.au](http://www.edp.com.au)

Illustration showing the edp Minibagger connected to a Net Bagger.

The **Minibagger with reversing conveyor** is ideal for the small business operator who wants to save on labour and increase their efficiency.

This entry level weigher is ideal for this operation.

**edp australia pty ltd**

33 - 37 O'Brien Street  
PO Box 251 Mooropna VIC 3629  
Australia

Phone: +61 3 5820 5337  
Fax: +61 3 5825 2758  
Email: [sales@edp.com.au](mailto:sales@edp.com.au)

*e-as-y as...*  
**edp**

# edp Minibagger

with Reversing Conveyor

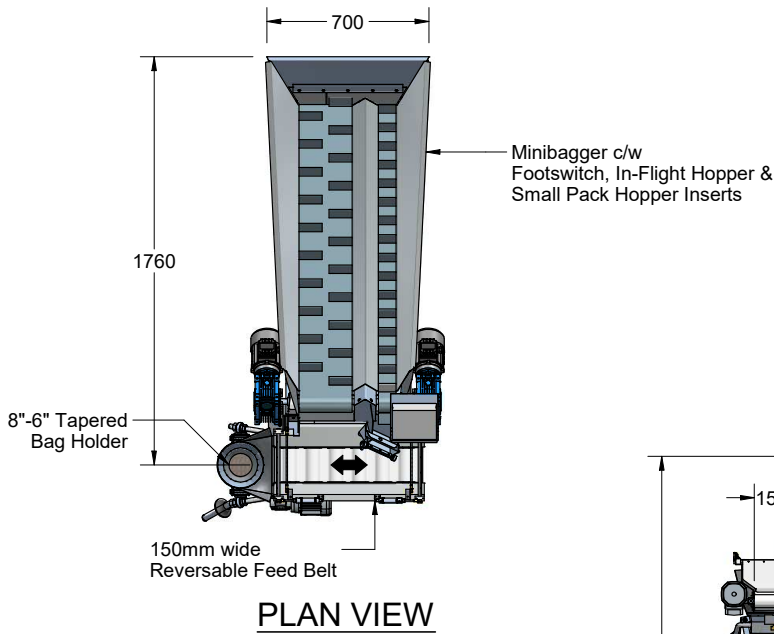

## SIDE VIEW

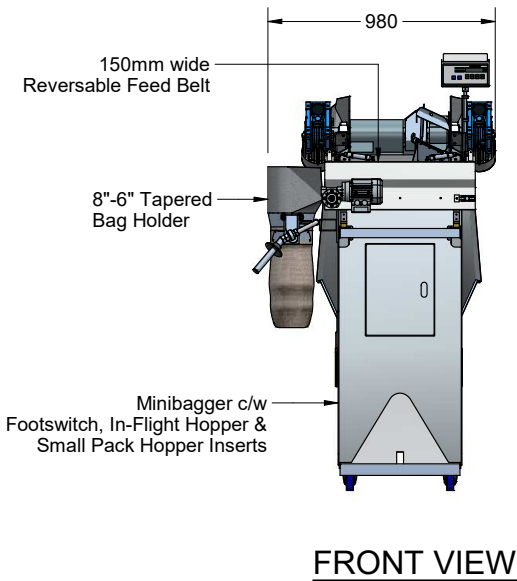
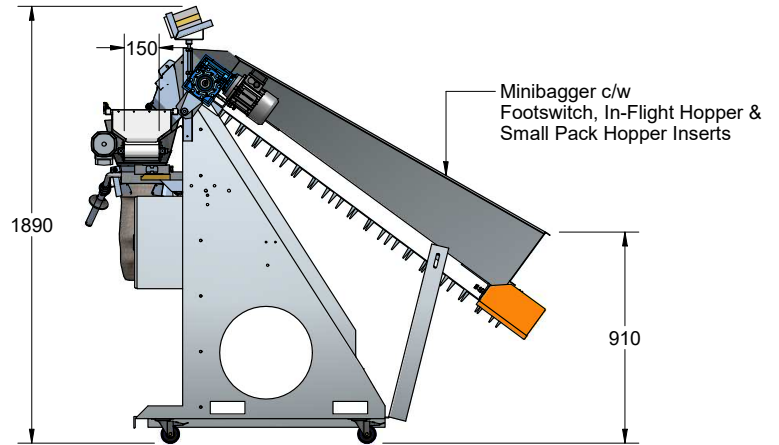

[www.edp.com.au](http://www.edp.com.au)

edp australia pty ltd

33 – 37 O'Brien Street  
PO Box 251 Mooropna VIC 3629  
Australia

Phone: +61 3 5820 5337  
Fax: +61 3 5825 2758  
Email: [sales@edp.com.au](mailto:sales@edp.com.au)

edp®